

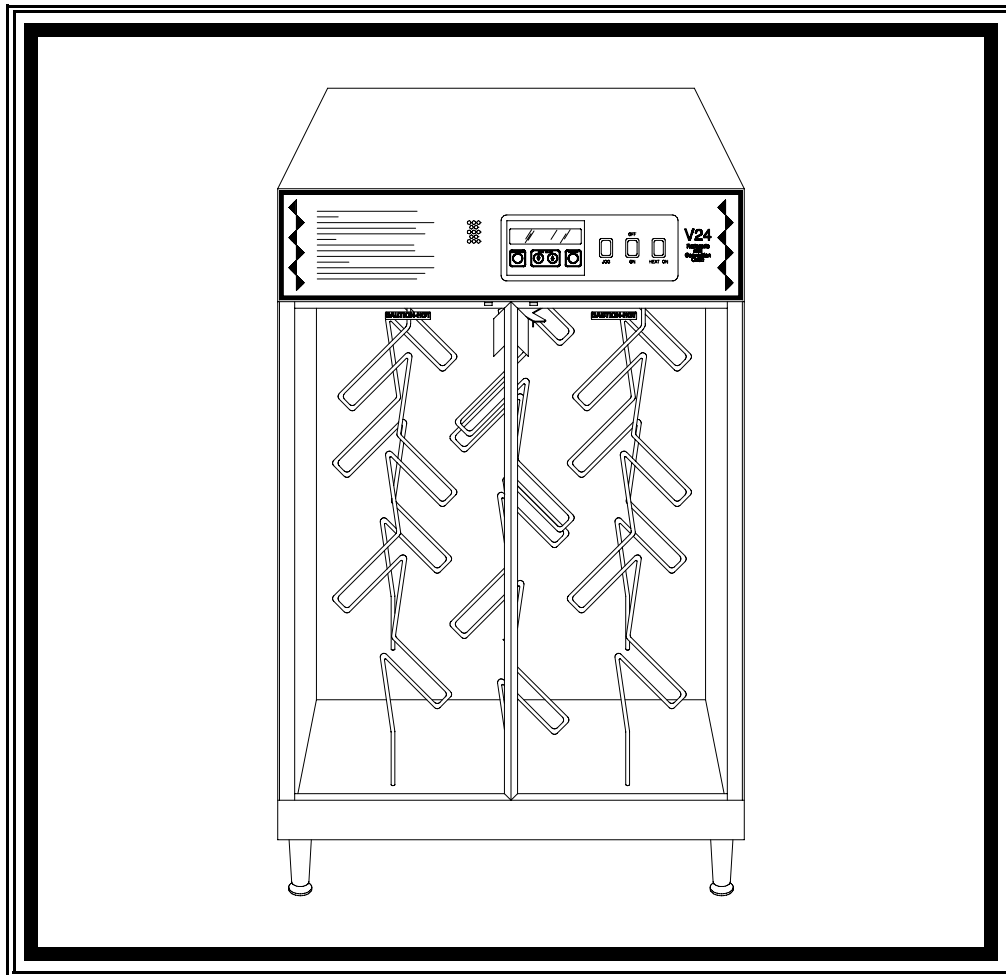

***"An American Tradition Since 1954!"***

**MODEL V24XP  
V24 VERTICAL ROTISSERIE  
INSTALLATION/OPERATION MANUAL**

**Be sure ALL installers read, understand, and have access to this manual at all times.**



**Bro-Tisserie Foods Division of The Broaster Company**  
2855 Cranston Road, Beloit, WI 53511-3991  
608/365-0193 [www.broaster.com](http://www.broaster.com)



**FOR YOUR SAFETY**

Do not use or store gasoline or other flammable vapors or liquids in the vicinity of this or any other appliance.



**WARNING:** Improper installation, adjustments, alteration, service or maintenance can cause property damage, injury or death. Read the installation, operating and maintenance instructions thoroughly before installing or servicing this equipment.

For the sake of safety and clarity, the following words used in this manual are defined as follows:



**DANGER:** Indicates an imminently hazardous situation which, if not avoided, could result in serious injury or death.



**WARNING:** Indicates a potentially hazardous situation which, if not avoided, could result in serious injury or death.



**CAUTION:** Indicates a potentially hazardous situation which, if not avoided, could result in minor injury, property damage or both.

All adjustments and repairs shall be made by an authorized Broaster Company representative.

If there is a power failure, turn cook/filter switch OFF. On the Model 2400GH, also slide switch on gas valve OFF. DO NOT attempt to operate unit during a power failure.

2400GH: Post, in prominent locations, instructions to be followed in the event that the user smells gas. This information can be obtained from your local gas supplier.



**WARNING:** Failure to read and understand this manual completely could result in serious injury or death. Be sure ALL operators read, understand and have access to this manual at all times.



**WARNING: DO NOT** keep soiled rags or other absorbent types of material under high temperature and/or in closed conditions in the presence of oxygen.



# TABLE OF CONTENTS

<b>1 - OWNER'S RESPONSIBILITY .....</b>	<b>1 - 1</b>
<b>2 - INSTALLATION.....</b>	<b>2 - 1</b>
LEVELING .....	2 - 1
Without Base .....	2 - 1
With Base .....	2 - 1
WIRING DIAGRAMS	
Export .....	2 - 2
<b>3 - ROTISSERIE OPERATION.....</b>	<b>3 - 1</b>
CONTROL PANEL .....	3 - 1
Familiarization .....	3 - 1
Main Menu.....	3 - 1
CONTROL PANEL Effective: V24B790013 .....	3 - 2
Familiarization .....	3 - 2
Main Menu.....	3 - 2
CONTROLLER PROGRAMMING .....	3 - 3
Products #1 - #10 .....	3 - 3
Standby 000F .....	3 - 3
OPERATION AND PREPARATION.....	3 - 4
Whole Chicken .....	3 - 5
Preparation.....	3 - 6
Starting A Cook Cycle .....	3 - 7
CLEANING .....	3 - 7
<b>4 - CONVECTION OPERATION .....</b>	<b>4 - 1</b>
DUCT VARIATIONS .....	4 - 1
Air Circulation System #1 .....	4 - 1
Air Circulation System #2 .....	4 - 2
PROGRAMMING.....	4 - 3
Products #1 - #10 .....	4 - 3
Standby 000F .....	4 - 4
Manual 000F .....	4 - 4
OPERATION.....	4 - 5
Starting A Cook Cycle .....	4 - 5
CLEANING .....	4 - 6

<b>5 - RECIPES.....</b>	<b>5 - 1</b>
BEEF AND PORK .....	5 - 1
Baby Back Pork Ribs.....	5 - 1
Fresh Top (Inside) or Bottom Round .....	5 - 2
Fresh Prime Rib .....	5 - 3
Fresh Pork Loin.....	5 - 4
Fresh Boston Butt Pork Roast.....	5 - 5
VEGETABLES .....	5 - 6
Fresh Potatoes .....	5 - 6
BREADS.....	5 - 7
Fresh Biscuits.....	5 - 7
Muffins (1 to 1 1/4 oz.).....	5 - 8
Muffins (1 1/2 to 2 oz.).....	5 - 9
Muffins (3 3/4 to 4 oz.).....	5 - 10
DESSERTS .....	5 - 11
Frozen Cookies .....	5 - 11
Frozen Fruit Pie.....	5 - 12
Frozen Custard Pie .....	5 - 13
MISCELLANEOUS.....	5 - 14
Frozen 20 oz. 12 Inch Pizza.....	5 - 14
Fresh Turkey .....	5 - 15

# 1 - OWNER'S RESPONSIBILITY

It is the owner's responsibility to:

- Insure the unit is properly maintained.
- Insure all safety devices and warning signs are in their original location and are legible.
- Allow only properly trained personnel to operate, clean and maintain your unit.
- Insure main power supply is disconnected before the unit is serviced.

When you sell, trade or give away your unit, you must make sure that all safety devices are intact, warning signs are legible and the Installation/Operation Manual is included with the unit.

If you need replacement warning signs or manuals, contact an authorized Broaster Company representative or The Broaster Company at 608/365-0193.

The Customer Service Department at The Broaster Company should be contacted at the time of sale or disposal of your unit so records may be updated.



## 2 - INSTALLATION

1. Install machine with minimum 3 inches clearance on sides and back
2. A remote circuit breaker or fuse should be installed in main power supply located in a path of exit and clearly identified.
3. All electrical work must conform to the requirements of national, state, and local electrical codes.
4. DO NOT apply a voltage to this unit other than shown on dataplate. If in doubt, consult your local power company.
5. The V24 is shipped 208 or 240 volts, 50/60 cycle, 9900 watts, with 3 phase wiring and is field convertible to single phase. Ratings are:

Phase	Volts	Amps	Wire	Fuse
1	220	51	#6	70
3	220/380 240/415	16 18	#8	25

6. Exhaust hood, if needed, should comply with national, state, and local codes.

### LEVELING

Leveling is important for proper door alignment.

#### Without Base:

1. Level unit front to back and side to side by adjusting feet.

#### With Base:

##### **Base with adjustable feet:**

1. See Without Base above.

##### **Base with casters:**

Casters are not adjustable for the purpose of leveling.

1. Be sure unit is installed on a level floor. If necessary, add additional blocking on a sloping floor.
2. Lock casters when leveling is complete.

V24 Export  
 Effective: V24B790013

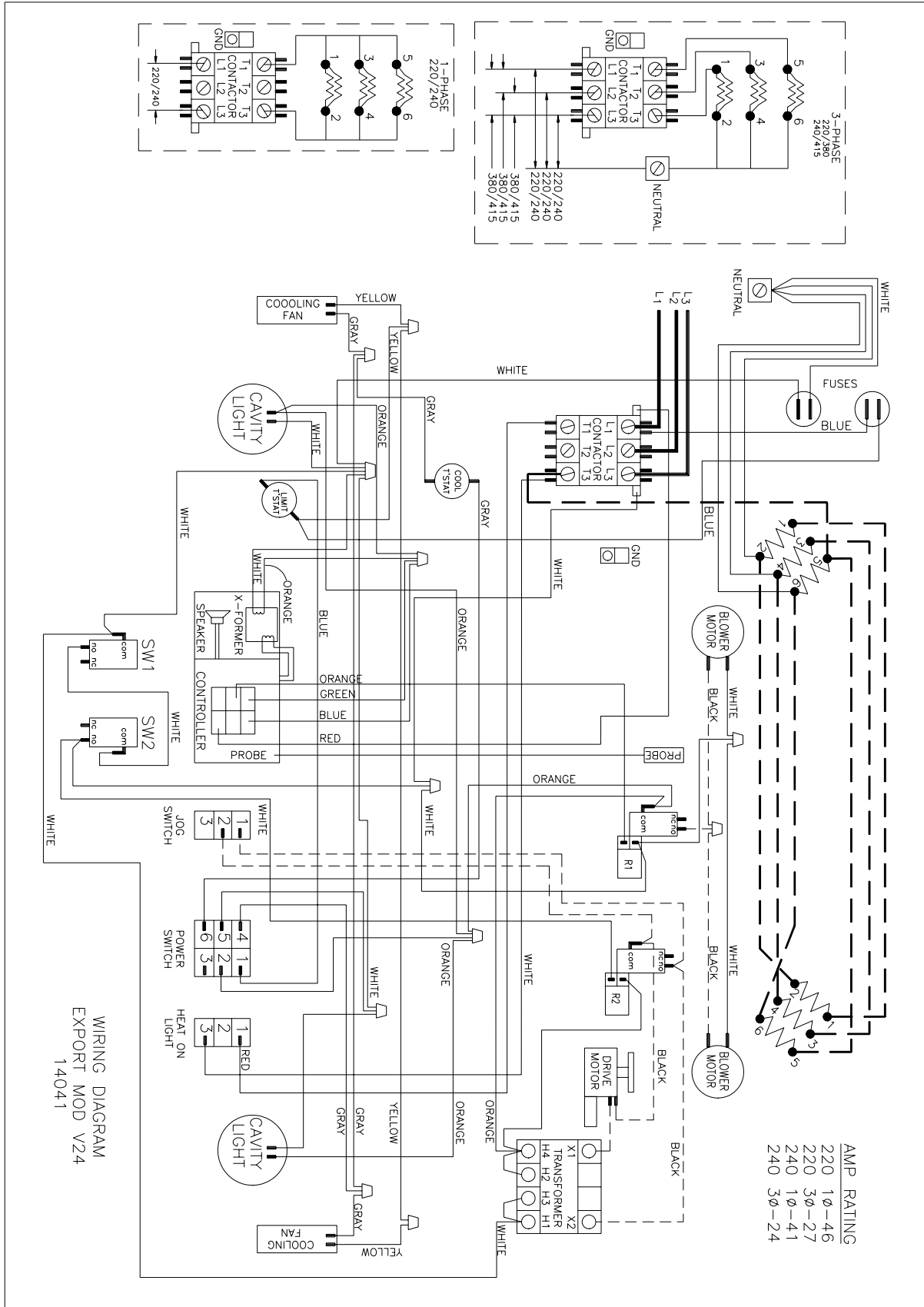

**V24 Export**  
**Effective: V24C40**

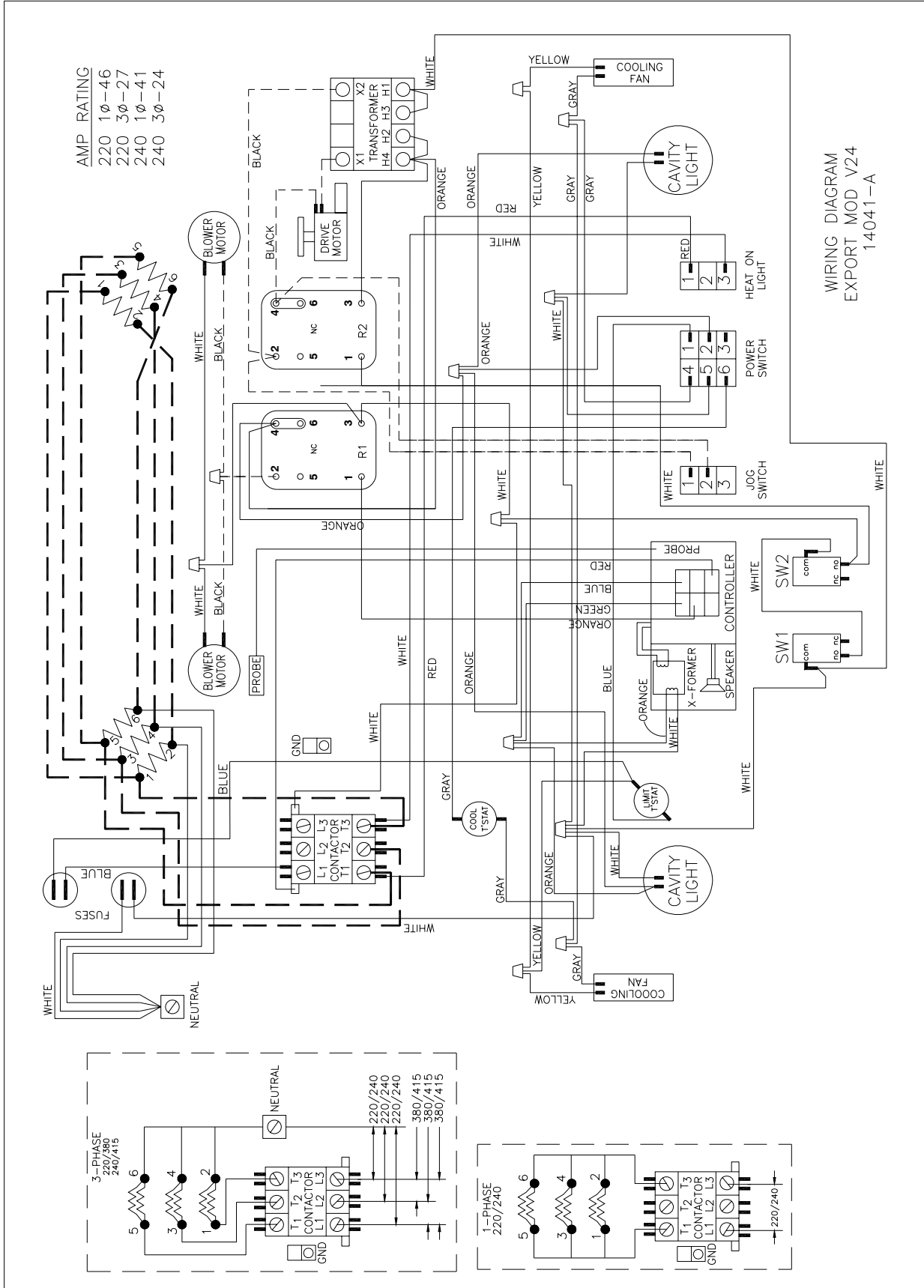



## 4 - CONVECTION OPERATION

### DUCT VARIATIONS

Convection kit (#14193) is required to cook products other than chicken. When installed, unit cooks as a convection oven.

**WARNING:** Be sure unit has cooled before installing convection kit. Hot surfaces could cause serious burns. Use hot mitts when handling unit components.

### AIR CIRCULATION SYSTEM #2:

Used when cooking **roasts, prime rib, pizza, cookies, pies, muffins, biscuits, etc.** The duct covers should force air toward the side panels and the upper duct should not be installed.

1. Disconnect main power supply.

2. Install duct cover (#13208) marked "R" by pushing onto left hand element duct. Slide cover down so bottom tab is inside bottom of element duct. Opening of duct must face the left side panel.

3. Install duct cover (#13227) marked "L" by pushing onto right hand element duct. Slide cover down so bottom tab is inside bottom of element duct. Opening of duct must face the right side panel.

4. Hang one convection rack side (#14478) between two of the spit carriage arms and the other between the opposite two arms so that they are across from each other with rungs toward center.

5. Install one shelf rack (#13240) into the bottom rung of the side racks. The others may be placed as needed.

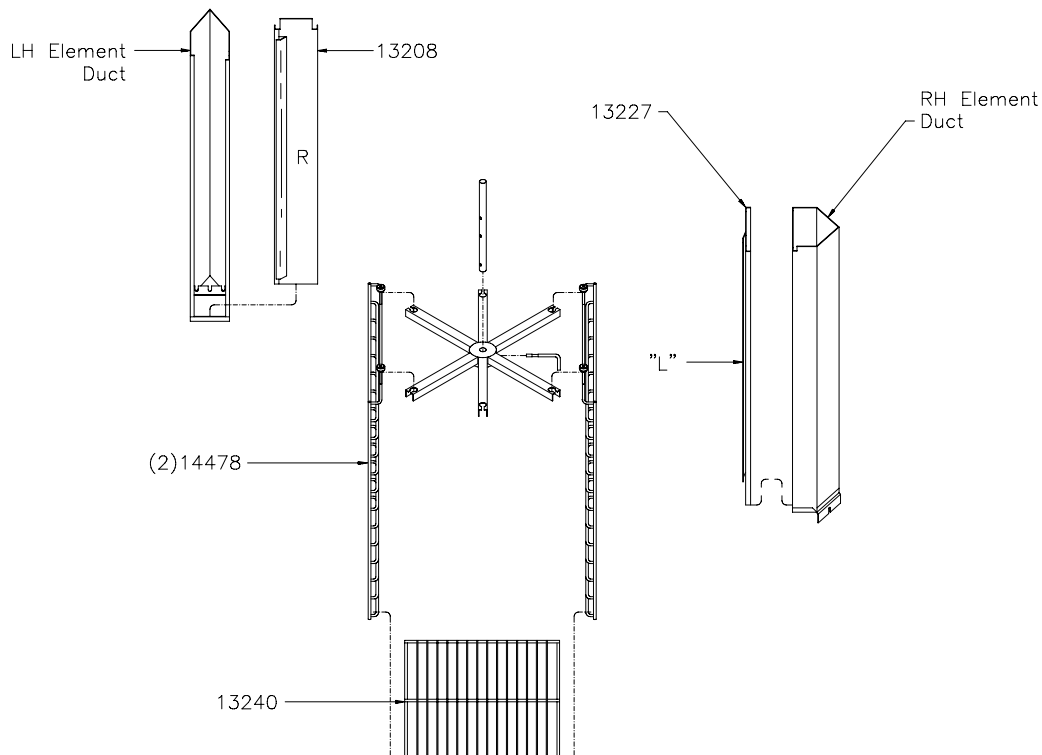

## AIR CIRCULATION SYSTEM #1:

Used when cooking **ribs only**. The duct covers should force air toward the back panel and the upper duct must be installed.

1. Disconnect main power supply.
2. Remove locking pin and spit carriage. See OPERATION AND PREPERATION in section 4.
3. Locate two upper duct tabs (#13244) and thumbscrews (#10925). Mount duct tabs to the top panel using the thumbscrews. Do not tighten thumb screws.
4. Turn duct tabs toward center of unit.
5. Install duct cover (#13227) marked "L" by pushing onto left hand element duct. Slide cover down so bottom tab is inside bottom of element duct. Opening of duct must face the back panel.
6. Install duct cover (#13208) marked "R" by pushing onto right hand element duct. Slide cover down so bottom tab is inside bottom of element duct. Opening of duct must face the back panel.
7. Install two holes (1) in upper duct onto pegs on back panel near top.
8. Turn duct tabs outward and under lip of upper duct. Tighten thumbscrews.
9. **Important:** Reinstall spit carriage by turning it upside down so the pin hole is above the arm. Slide hub onto drive shaft and insert drive pin (#13163).
10. Hang one convection rack side (#14478) between two of the spit carriage arms and the other between the opposite two arms so that they are across from each other.
11. Install one shelf rack (#13240) into the bottom rung of the side racks. The others may be placed as needed.

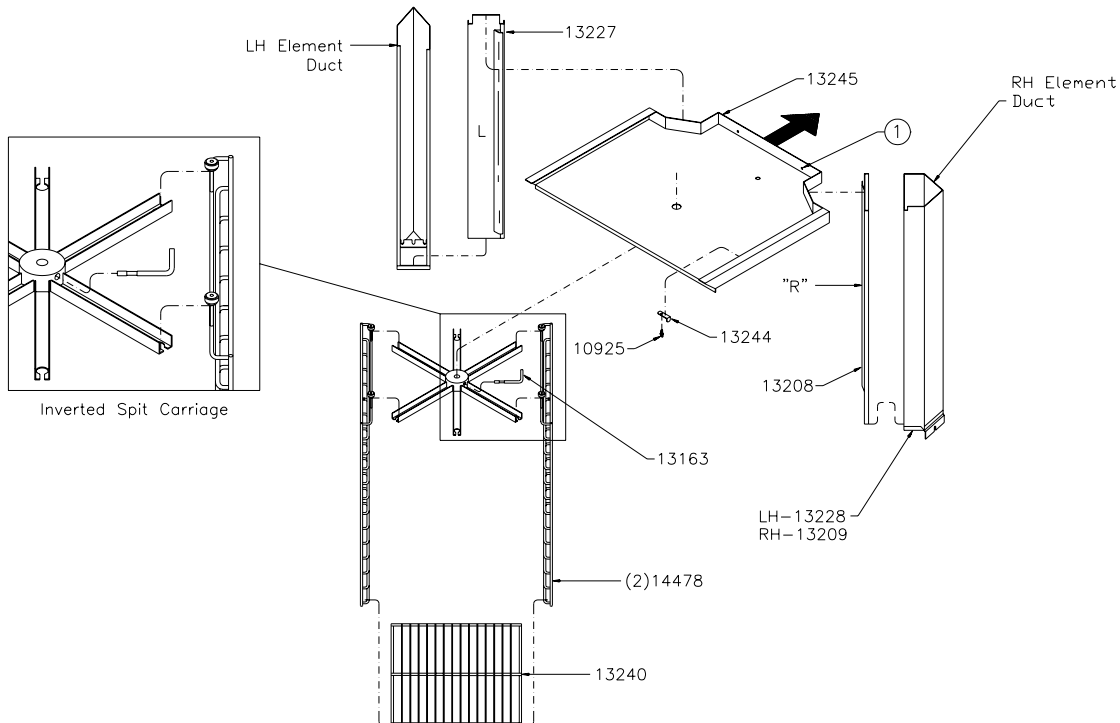

## **PROGRAMMING**

---

### **PRODUCTS #1 - #10:**

A = Operator **Action**

R = Controller **Response**

#### **Convection Cooking (Baking):**

A: Press the UP or DOWN buttons to select PRODUCT #1 - #10. Press and hold PROGRAM button until controller enters program mode.

R: Display reads TYPE? CONVECTION, COOK AND HOLD, or SLOW COOK AND HOLD.

A: Press UP or DOWN buttons to select CONVECTION. Press PROGRAM button.

R: Display reads OVEN COOK TEMP = 000F.

A: Press UP or DOWN buttons to make first digit selection. Press PROGRAM button. Repeat for last two digits.

R: Display reads AUTO COMPENSATE: ON or OFF. AUTO COMPENSATE will not appear in programming unless programmed OVEN COOK TEMP is above 300F.

AUTO COMPENSATE indicates timing method. When OFF, controller operates as a regular timer. When ON, controller monitors interior temperature and adjusts time to compensate for temperature fluctuations. Time will have to be adjusted for larger product and frozen product.

A: Press UP or DOWN buttons to make selection. Press PROGRAM button.

R: Display reads COOK TIME = 00:00:00.

A: Press UP or DOWN buttons to make first digit selection. Press PROGRAM button. Repeat for last five digits. Press PROGRAM button to exit program mode.

R: Controller returns to main menu.

#### **Cook and Hold or Slow Cook and Hold (Roasting):**

A: Press UP or DOWN buttons to select PRODUCT #1 - #10. Press and hold PROGRAM button until controller enters program mode.

R: Display reads TYPE? CONVECTION, COOK AND HOLD, or SLOW COOK AND HOLD.

A: Press UP or DOWN buttons to select COOK AND HOLD or SLOW COOK AND HOLD. Press PROGRAM button.

R: Display reads HOLD MODE: ON or OFF.

A: Press UP or DOWN buttons to make selection. Select ON to cook and hold or OFF to cook and serve. Press PROGRAM button.

R: Display reads OVEN COOK TEMP = 000F.

A: Press UP or DOWN buttons to make first digit selection. Press PROGRAM button. Repeat for last two digits.

Continued:

R: Display reads AUTO COMPENSATE: ON or OFF. AUTO COMPENSATE will not appear in programming unless programmed OVEN COOK TEMP is above 300F.

AUTO COMPENSATE indicates timing method. When OFF, controller operates as a regular timer. When ON, controller monitors interior temperature and adjusts time to compensate for temperature fluctuations. Time will have to be adjusted for larger product and frozen product.

A: Press UP or DOWN buttons to make selection. Press PROGRAM button.

R: Display reads COOK TIME = 00:00:00.

A: Press UP or DOWN buttons to make first digit selection. Press PROGRAM button. Repeat for last five digits. Press PROGRAM button to exit program mode.

OR

R: If HOLD MODE is ON, display reads #00 HLD = 000F 00:00.

A: Press UP or DOWN buttons to make first digit selection. Press PROGRAM button. Repeat for last two digits. Press PROGRAM button to exit program mode.

R: Controller returns to main menu.

#### STANDBY 000F:

A = Operator **Action**

R = Controller **Response**

A: Press UP or DOWN buttons to select STANDBY 000F. Press and hold PROGRAM button until controller enters program mode.

R: display reads STANDBY: 000F.

A: Press UP or DOWN buttons to make first digit selection. Press PROGRAM button. Repeat for last two digits. Press PROGRAM button to exit program mode.

R: Controller returns to main menu.

#### MANUAL 000F:

A = Operator **Action**

R = Controller **Response**

A: Press UP or DOWN buttons to select MANUAL 000F. Press PROGRAM button.

R: Display reads OVEN COOK TEMP = 000F.

A: Press UP or DOWN buttons to make first digit selection. Press PROGRAM button. Repeat for last two digits.

R: Display reads COOK TIME = 00:00:00.

A: Press UP or DOWN buttons to make first digit selection. Press PROGRAM button. Repeat for last five digits. Press PROGRAM button to exit program mode.

R: Controller returns to main menu.

## OPERATION

---

 **WARNING:** All surfaces are HOT. Hot surfaces could cause serious burns. Use hot mitts when handling unit components.

1. Install drip pan with drain plug into bottom of unit.

OR

Effective V24D790113: Install drain plug into bottom of unit.

2. Install drain pan on rails beneath drip pan.

**Note:** When draining drip pan, remember the capacity of drip pan exceeds capacity of drain pan.

3. Add 3/4 to 1 gallon of water into drip pan.

**Note:** The V24 regulates temperature to the main menu displayed. Therefore before placing product in unit for cooking, allow interior temperature to reach programmed temperature.

A = Operator **Action**  
R = Controller **Response**

A: Turn power switch ON.

R: Display reads STANDBY: 000F.

A: Press UP or DOWN buttons to select desired main menu item. See desired recipe for programming settings. Pull and lock gear drive release to stop rack weldment rotation. Place product in unit for cooking. Push gear drive release in.

OR

Effective: V24B790013 - Press UP or DOWN buttons to select desired main menu item. See desired recipe for programming settings. Open doors and press and hold JOG switch to control rack weldment rotation. Place product in unit for cooking. Close doors.

### STARTING A COOK CYCLE:

A = Operator **Action**  
R = Controller **Response**

If required, press and hold START/STOP button for several seconds to terminate a hold or cook cycle.

A: Press START/STOP button to start cooking cycle.

R: Display reads time countdown.

OR

Display reads hold time counting up after a cook cycle if HOLD MODE is ON.

A: When desired, terminate hold cycle. Pull and lock gear drive release to stop rack weldment rotation. Remove product from unit.

OR

Effective: V24B790013 - When desired, terminate hold cycle. Open doors and press and hold JOG switch to control rack weldment rotation. Remove product from unit.

## CLEANING

---



**CAUTION:** Use only food approved cleaners.



**WARNING:** Wait for unit to cool before cleaning. Hot surfaces could cause serious burns. Do not attempt to clean hot glass. Glass may break causing serious cuts.

Clean once daily. Use oven cleaner on hard to clean surfaces. After washing any interior component or surface, rinse with vinegar and water solution (1/2 cup vinegar per gallon of water), and rinse thoroughly with clear water.

1. Disconnect main power.
2. Remove doors by fully opening and lifting up and out on bottom; set in sink for cleaning. Do not use abrasive cleaners on glass. To install doors, insert upper pin first followed by lower pin.

**Note:** When draining drip pan, remember the capacity of drip pan exceeds capacity of drain pan.

3. Remove rack and set in sink for cleaning. Remove drain plug in bottom of drip pan. Use scraper to empty drip pan. Remove drip pan and set in sink for cleaning.

OR

Effective V24D790113: Wipe drip pan clean using clean cloth or paper towel.

4. Empty drain pan. Set in sink for cleaning.
5. Remove upper and element air duct's. Set in sink for cleaning.
6. Loosen thumb screw's on bottom of heating element duct's and remove. Set in sink for cleaning.
7. Clean interior and exterior surfaces.
8. Sanitize components and surfaces according to standard health regulations after washing.

# 5 - RECIPES

All cook times are suggested. Due to variations in product weight and desired doneness, time, temperature, or both may have to be adjusted.

## **BEEF AND PORK**

### **BABY BACK PORK RIBS:**

See Air Circulation System #1.  
 MAX LOAD . . . . 36 slabs (3 slabs per rack)  
 MAX HOLD TIME . . . . . 03:00:00

### **Special Instructions:**

1. Remove membrane.
2. Marinate ribs in stainless steel or plastic container with 4 oz. Broaster Rib-ite per gallon of water, be sure ribs are covered with marinade.

3. Marinate 8 hours minimum 12 hours maximum (overnight preferred).
4. Drain marinade and sprinkle each side of slab with 1 tablespoon Broaster Foods Barbecue Seasoning and rub in lightly.
5. Final internal temperature of meat is 160 to 170F.

### **Optional:**

1. Add 1 fl. oz. Mist-Aire Liquid Smoke per gallon of marinade.
2. Half hour before completion of hold cycle, brush each side of slab with Cranston Farms Country Style BBQ Sauce.

SIZE	SUGGESTED COOK AND SERVE TIMES <small>Remove product at end of cook cycle to prevent over cooking.</small>	SUGGESTED COOK AND HOLD TIMES
1 3/4 to 2 lbs. per slab	01:45:00 00:30:00 min. additional per 1/2 lb. per slab	N/A
2 to 3 lbs. per slab	See Above	N/A
PROGRAM ITEM	SUGGESTED COOK AND SERVE SETTINGS	SUGGESTED COOK AND HOLD SETTINGS
TYPE?	SLOW COOK AND HOLD	N/A
HOLD MODE	OFF/ON	N/A
OVEN COOK TEMP	250F	N/A
AUTO COMPENSATE	N/A	N/A
COOK TIME	see time chart above	N/A
HOLD TEMP	155F	N/A

**FRESH TOP (INSIDE) or BOTTOM ROUND:**

See Air circulation System #2.

MAX LOAD ..... 80 lbs.

(2 - 20 lb. roasts per rack; 2 racks used)

MIN HOLD TIME ..... 05:00:00

MAX HOLD TIME ..... 20:00:00

**Special Instructions:**

1. Cook roasts unwrapped.
2. Set roasts directly on rack, not in pans.
3. Final internal temperature of meat:
  - Rare .....130 to 140F
  - Medium .....140 to 150F
  - Well .....150 to 150F

**Optional:**

1. Season with Broaster Foods Prep Seasoning if desired.

SIZE	SUGGESTED COOK AND SERVE TIMES <small>Remove product at end of cook cycle to prevent over cooking.</small>	SUGGESTED COOK AND HOLD TIMES
15 to 20 lb. roast	N/A	00:13:00 min. per lb. for first roast 00:20:00 min. per additional roast

PROGRAM ITEM	SUGGESTED COOK AND SERVE SETTINGS	SUGGESTED COOK AND HOLD TIMES
TYPE?	N/A	SLOW COOK AND HOLD
HOLD MODE	N/A	ON
OVEN COOK TEMP	N/A	250F
AUTO COMPENSATE	N/A	N/A
COOK TIME	N/A	see time chart above
HOLD TEMP	N/A	150F rare 155F medium 160F well

**FRESH PRIME RIB:**

See Air Circulation System #2.

MAX LOAD ..... 80 lbs.

(2 - 20 lb. roasts per rack; 2 racks used)

MIN HOLD TIME ..... 04:00:00

MAX HOLD TIME ..... 22:00:00

**Special Instructions:**

1. Purchase with exterior fat cap.
2. Cook unwrapped.
3. Set directly on rack, not in pans.
4. Final internal temperature of meat:
  - Rare .....130 to 140F
  - Medium .....140 to 150F
  - Well .....150 to 160F

**Optional:**

1. Season with Broaster Foods Prep if desired.

SIZE	SUGGESTED COOK AND SERVE TIMES <small>Remove product at end of cook cycle to prevent over cooking.</small>	SUGGESTED COOK AND HOLD TIMES
15 to 20 lb.	N/A	00:08:00 min. per lb. for first prime 00:20:00 min. per additional prime

PROGRAM ITEM	SUGGESTED COOK AND SERVE SETTINGS	SUGGESTED COOK AND HOLD SETTINGS
TYPE?	N/A	SLOW COOK AND HOLD
HOLD MODE	N/A	ON
OVEN COOK TEMP	N/A	250F
AUTO COMPENSATE	N/A	N/A
COOK TIME	N/A	see time chart above
HOLD TEMP	N/A	150F rare 155F medium 160F well

**FRESH PORK LOIN:**

See Air Circulation System #2.

MAX LOAD ..... 72 lbs.

(2 - 12 lb. roasts per rack; 3 racks used)

MIN HOLD TIME ..... 05:00:00

MAX HOLD TIME ..... 10:00:00

**Special Instructions:**

1. Cook unwrapped.
2. Set directly on rack, not in pans.
3. Final internal temperature of meat is 160 to 170F.

**Option:**

1. Season with Broaster Foods Prep if desired.

SIZE	SUGGESTED COOK AND SERVE TIMES <small>Remove product at end of cook cycle to prevent over cooking.</small>	SUGGESTED COOK AND HOLD TIMES
8 - 12 lb.	N/A	00:24:00 min. per lb. for first loin 00:05:00 min. per additional full rack

PROGRAM ITEM	SUGGESTED COOK AND SERVE SETTINGS	SUGGESTED COOK AND HOLD SETTINGS
TYPE?	N/A	SLOW COOK AND HOLD
HOLD MODE	N/A	ON
OVEN COOK TEMP	N.A	250F
AUTO COMPENSATE	N/A	N/A
COOK TIME	N/A	see time chart above
HOLD TEMP	N/A	170F

**FRESH BOSTON BUTT PORK ROAST:**

See Air Circulation System #2.

MAX LOAD ..... 80 lbs.

(4 - 5 lb. roasts per rack; 4 racks used)

MIN HOLD TIME ..... 03:00:00

MAX HOLD TIME ..... 05:00:00

**Special Instructions:**

1. Cook unwrapped.
2. Set directly on rack, not in pans.
3. Final internal temperature of meat is 160 to 170F.

**Optional:**

1. Season with Broaster Foods Prep if desired.

SIZE	SUGGESTED COOK AND SERVE TIMES <small>Remove product at end of cook cycle to prevent over cooking.</small>	SUGGESTED COOK AND HOLD TIMES
4 to 6 lb.	N/A	00:36:00 min. per lb. for first roast 00:05:00 min. per additional full rack

PROGRAM ITEM	SUGGESTED COOK AND SERVE SETTINGS	SUGGESTED COOK AND HOLD SETTINGS
TYPE?	N/A	SLOW COOK AND HOLD
HOLD MODE	N/A	ON
OVEN COOK TEMP	N/A	250F
AUTO COMPENSATE	N/A	N/A
COOK TIME	N/A	see time chart above
HOLD TEMP	N/A	170F

**VEGETABLES**

**FRESH POTATOES:**

See Air Circulation System #2.

MAX LOAD ..... 72 potatoes  
(12 potatoes per rack; 6 racks used)

**Special Instructions:**

1. Cook unwrapped.
2. Set directly on rack, not in pans.

**Optional:**

1. Season with Broaster Foods Prep if desired.

QUANTITY	SUGGESTED COOK AND SERVE TIMES Remove product at end of cook cycle to prevent over cooking.	SUGGESTED COOK AND HOLD TIMES
72 potatoes	00:01:00	N/A

PROGRAM ITEM	SUGGESTED COOK AND SERVE SETTINGS	SUGGESTED COOK AND HOLD SETTINGS
TYPE?	CONVECTION	N/A
HOLD MODE	N/A	N/A
OVEN COOK TEMP	400F	N/A
AUTO COMPENSATE	ON	N/A
COOK TIME	see time chart above	N/A
HOLD TEMP	N/A	N/A

# **BREADS**

---

## **FRESH BISCUITS:**

See Air Circulation System #2.

MAX LOAD .....216 Biscuits  
(36 biscuits per rack; 6 racks used)

### **Special Instructions:**

1. Place biscuits on lightly greased cookie sheet.
2. Brush with butter immediately after removing from **oven**.

<b>PROGRAM ITEM</b>	<b>SUGGESTED COOK AND SERVE SETTINGS</b>	<b>SUGGESTED COOK AND HOLD SETTINGS</b>
TYPE?	CONVECTION	N/A
HOLD MODE	N/A	N/A
OVEN COOK TEMP	400F	N/A
AUTO COMPENSATE	ON	N/A
COOK TIME	00:23:00	N/A
HOLD TIME	N/A	N/A

**MUFFINS (1 TO 1 1/4 oz.):**

See Air Circulation System #2.

MAX LOAD ..... 144 muffins  
(24 muffins per rack; 6 racks used)

**Special Instructions:**

1. Using a #30 scoop, put batter in lightly greased or paper-lined muffin tin.  
Dimension of muffin cup: 2 3/4" top; 1 1/2" bottom; 1 1/8" deep.

<b>PROGRAM ITEM</b>	<b>SUGGESTED COOK AND SERVE SETTINGS</b>	<b>SUGGESTED COOK AND HOLD SETTINGS</b>
TYPE?	CONVECTION	N/A
HOLD MODE	N/A	N/A
OVEN COOK TEMP	375F	N/A
AUTO COMPENSATE	ON	N/A
COOK TIME	00:14:00 to 00:17:00	N/A
HOLD TEMP	N/A	N/A

**MUFFINS (1 1/2 TO 2 oz.):**

See Air Circulation System #2.

MAX LOAD . . . . . 144 muffins  
(24 muffins per rack; 6 racks used)

**Special Instructions:**

1. Using a #20 scoop, put batter in lightly greased or paper-lined muffin tin.  
Dimension of muffin cup: 2 3/4" top; 1 3/4" bottom; 1 1/4" deep.

<b>PROGRAM ITEM</b>	<b>SUGGESTED COOK AND SERVE SETTINGS</b>	<b>SUGGESTED COOK AND HOLD SETTINGS</b>
TYPE?	CONVECTION	N/A
HOLD MODE	N/A	N/A
OVEN COOK TEMP	375F	N/A
AUTO COMPENSATE	ON	N/A
COOK TIME	00:20:00 to 00:23:00	N/A
HOLD TEMP	N/A	N/A

**MUFFINS (3 3/4 TO 4 oz.):**

See Air Circulation System #2.

MAX LOAD ..... 72 muffins  
(12 muffins per rack; 6 racks used)

**Special Instructions:**

1. Using a #8 scoop, put batter in lightly greased or paper-lined muffin tin.  
Dimension of muffin cup: 3 1/2" top; 2 3/4" bottom; 1 1/4" deep.

<b>PROGRAM ITEM</b>	<b>SUGGESTED COOK AND SERVE SETTINGS</b>	<b>SUGGESTED COOK AND HOLD SETTINGS</b>
TYPE?	CONVECTION	N/A
HOLD MODE	N/A	N/A
OVEN COOK TEMP	375F	N/A
AUTO COMPENSATE	ON	N/A
COOK TIME	00:22:00 to 00:25:00	N/A
HOLD TEMP	N/A	N/A

# DESSERTS

---

## FROZEN COOKIES:

See Air Circulation System #2.

MAX LOAD .....144 cookies  
 (12 cookies per rack; 12 racks used)

### **Special Instructions:**

1. Place cookies on lightly greased cookie sheets.

PROGRAM ITEM	SUGGESTED COOK AND SERVE SETTINGS	SUGGESTED COOK AND HOLD SETTINGS
TYPE?	CONVECTION	N/A
HOLD MODE	N/A	N/A
OVEN COOK TEMP	350F	N/A
AUTO COMPENSATE	ON	N/A
COOK TIME	00:12:00 to 00:15:00	N/A
HOLD TEMP	N/A	N/A

**FROZEN FRUIT PIE:**

See Air Circulation System #2.

MAX LOAD ..... 12 pies  
(2 pies per rack; 6 racks used)

**Special Instructions:**

1. Place pies directly on racks.

<b>PROGRAM ITEM</b>	<b>SUGGESTED COOK AND SERVE SETTINGS</b>	<b>SUGGESTED COOK AND HOLD SETTINGS</b>
TYPE?	CONVECTION	N/A
HOLD MODE	N/A	N/A
OVEN COOK TEMP	375F	N/A
AUTO COMPENSATE	ON	N/A
COOK TIME	01:25:00	N/A
HOLD TEMP	N/A	N/A

**FROZEN CUSTARD PIE:**

See Air Circulation System #2.

MAX LOAD ..... 12 pies  
(2 pies per rack; 6 racks used)

**Special Instructions:**

1. Place pies directly on racks.
2. Allow pies to cool one hour after baking so filing can “set-up”.

<b>PROGRAM ITEM</b>	<b>SUGGESTED COOK AND SERVE SETTINGS</b>	<b>SUGGESTED COOK AND HOLD SETTINGS</b>
TYPE?	CONVECTION	N/A
HOLD MODE	N/A	N/A
OVEN COOK TEMP	350F	N/A
AUTO COMPENSATE	ON	N/A
COOK TIME	01:30:00	N/A
HOLD TEMP	N/A	N/A

**MISCELLANEOUS**

**FROZEN 20 oz. 12 INCH PIZZA:**

See Air Circulation System #2.

MAX LOAD .....12 pizzas  
 (1 pizza per rack; 12 racks used)

**Special Instructions:**

1. Place pizzas directly on racks.

<b>PROGRAM ITEM</b>	<b>SUGGESTED COOK AND SERVE SETTINGS</b>	<b>SUGGESTED COOK AND HOLD SETTINGS</b>
TYPE?	CONVECTION	N/A
HOLD MODE	N/A	N/A
OVEN COOK TEMP	375F	N/A
AUTO COMPENSATE	ON	N/A
COOK TIME	00:20:00	N/A
HOLD TEMP	N/A	N/A

**FRESH TURKEY:**

See Air Circulation System #2.

MAX LOAD ..... 2 turkeys

(1-20 lb. turkey per rack; 2 racks used)

MAX HOLD TIME ..... 08:00:00

**Special Instructions:**

1. Purchase 15 - 20 lb. turkeys.
2. Set birds directly on rack, not in pans.
3. Final internal temperature of meat:  
 Breast ..... 170F  
 Thigh ..... 180F

**Optional:**

1. Brush bird(s) with oil if desired.
2. Season with Broaster Foods Prep if desired.

SIZE	SUGGESTED COOK AND SERVE TIMES <small>Remove product at end of cook cycle to prevent over cooking.</small>	SUGGESTED COOK AND HOLD TIMES
15 to 20 lb. turkey	00:16:00 min. per lb. for first turkey 00:20:00 min. per additional turkey	N/A

PROGRAM ITEM	SUGGESTED COOK AND SERVE SETTINGS	SUGGESTED COOK AND HOLD SETTINGS
TYPE?	SLOW COOK AND HOLD	N/A
HOLD MODE	ON	N/A
OVEN COOK TEMP	270F	N/A
AUTO COMPENSATE	N/A	N/A
COOK TIME	see time chart above	N/A
HOLD TEMP	170F	N/A