

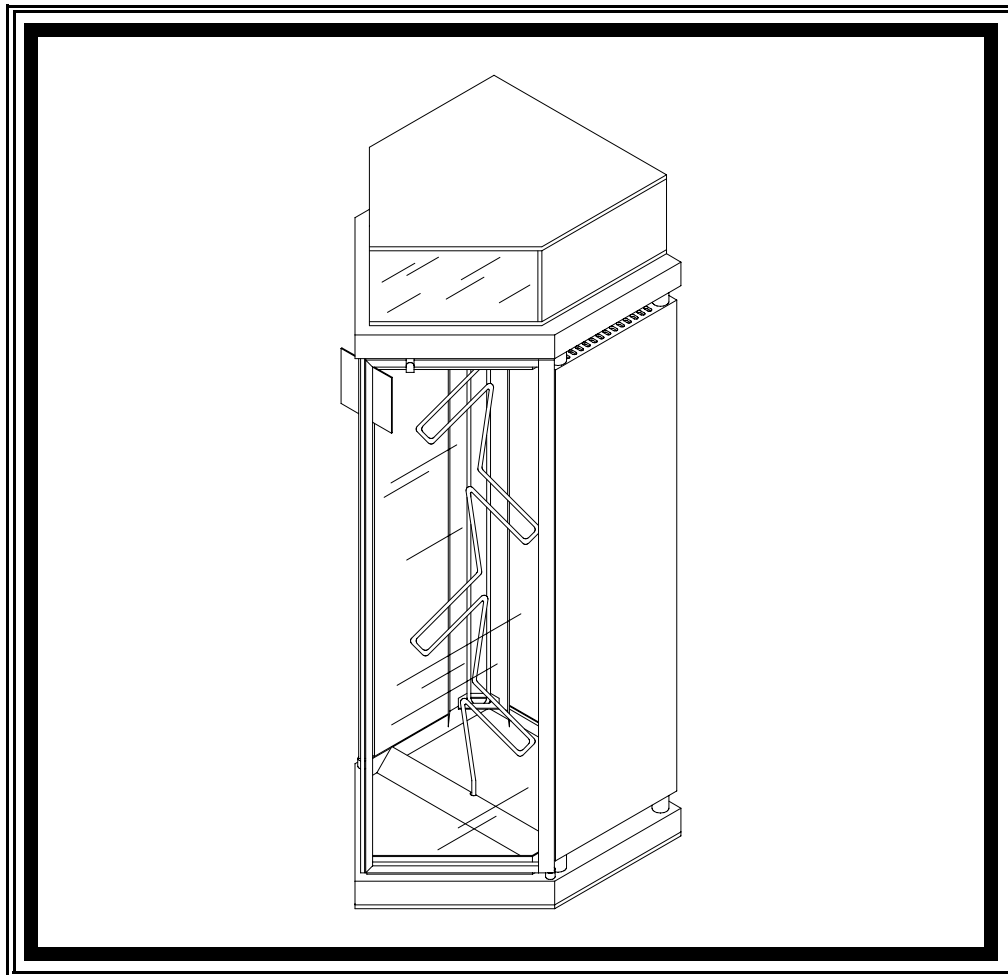

*"An American Tradition Since 1954!"*

**MODEL V4XP  
VERTICAL ROTISSERIE  
OPERATION AND PARTS MANUAL**

**Be sure ALL installers read, understand, and have access to this manual at all times.**



**Bro-Tisserie Foods Division of The Broaster Company**  
2855 Cranston Road, Beloit, WI 53511-3991  
608/365-0193 [www.broaster.com](http://www.broaster.com)



**FOR YOUR SAFETY**

Do not use or store gasoline or other flammable vapors or liquids in the vicinity of this or any other appliance.



**WARNING:** Improper installation, adjustments, alteration, service or maintenance can cause property damage, injury or death. Read the installation, operating and maintenance instructions thoroughly before installing or servicing this equipment.

For the sake of safety and clarity, the following words used in this manual are defined as follows:



**DANGER:** Indicates an imminently hazardous situation which, if not avoided, could result in serious injury or death.



**WARNING:** Indicates a potentially hazardous situation which, if not avoided, could result in serious injury or death.



**CAUTION:** Indicates a potentially hazardous situation which, if not avoided, could result in minor injury, property damage or both.

All adjustments and repairs shall be made by an authorized Broaster Company representative.

If there is a power failure, turn power switch OFF. DO NOT attempt to operate unit during a power failure.



**WARNING:** Failure to read and understand this manual completely could result in serious injury or death. Be sure ALL operators read, understand and have access to this manual at all times.



**WARNING:** Rags or papers containing cooking oil can catch fire if exposed to heat. Laundering will not remove the oil. Dispose of all oil-soiled papers and rags in a trash container that is in a ventilated area away from all cooking equipment or other heat sources such as direct sunlight.



For the sake of safety and clarity, the following words used in this manual are defined as follows:

**CAUTION:** Indicates a potentially hazardous situation which, if not avoided, could result in minor injury, property damage, or both.

**WARNING:** Indicates a potentially hazardous situation which, if not avoided, could result in serious injury or death.

- All adjustments and repairs shall be made by an authorized Broaster Company representative.
- A current written trademark authorization must be obtained from The Broaster Company to use the Bro-Tisserie® trademark.

## INSTALLATION

- See PERMANENT MOUNTING INSTRUCTIONS.
- Unit must be alone on a 15 amp circuit. Be sure installation meets all applicable codes.

**WARNING:** Electrical Grounding Instructions - Each unit is equipped with a three-prong (grounding) plug for your protection against shock hazard and should be plugged directly into a properly grounded three-prong receptacle. DO NOT cut or remove grounding prong from this plug.

## WIRING DIAGRAMS

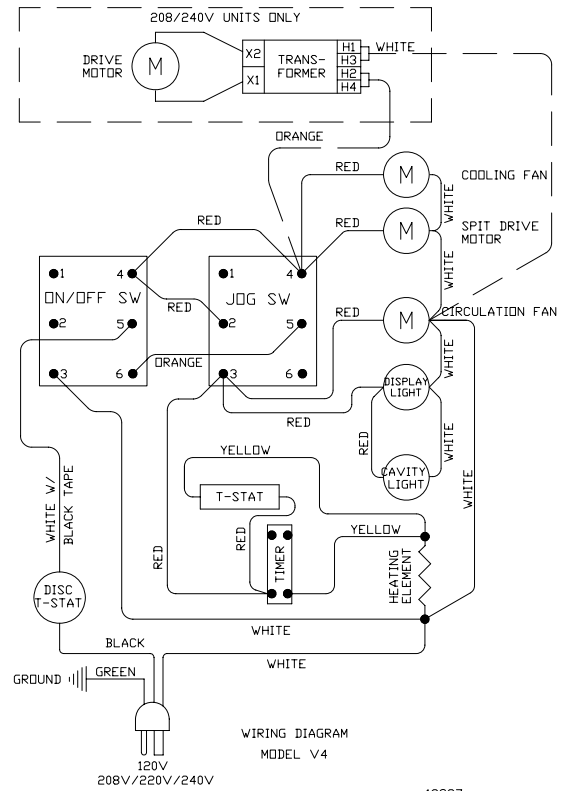

### Effective: V4CB790084

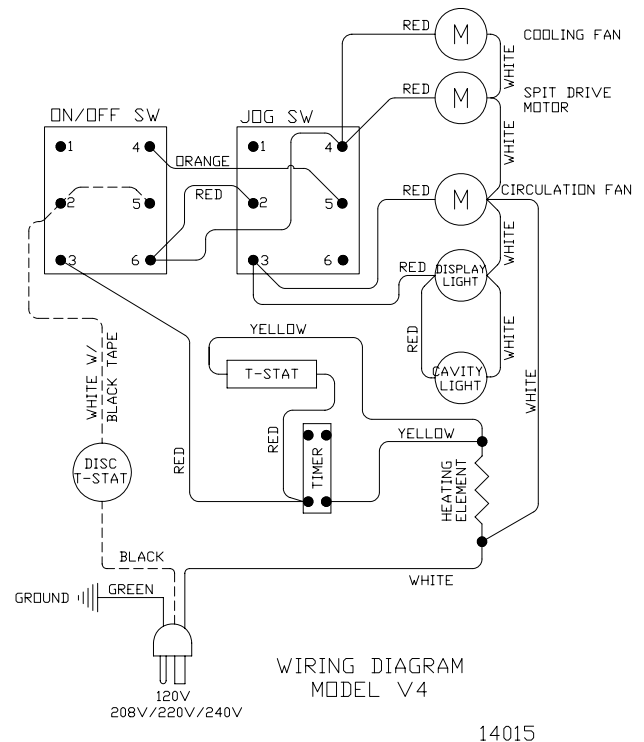

## CONTROL PANEL FAMILIARIZATION

 **CAUTION:** Follow CLEANING instructions as outlined in this manual before operating the first time.

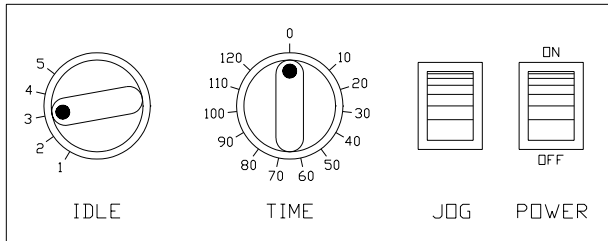

1. Power Switch: This switch has two positions: ON and OFF.
2. Jog Switch: Gradually turns spit for easy removal of product when POWER is OFF.
3. Timer: Indicates cooking time. Timer switches to IDLE when TIME reaches 0.
4. Idle: When TIME reaches 0, IDLE regulates temperature.

## PRODUCT PREPARATION AND COOKING

### Preparation:

1. Purchase good quality whole chickens  $\pm 1/4$  lb. for consistent results. Maximum bird weight should not exceed 3.25 lbs.
2. Preheat unit by turning POWER switch ON and TIME to 20. Set IDLE to 3.
3. Place drip pan into unit bottom; add  $1/8$ " water.
4. Unit capacity is four birds. Trim excess skin and fat, remove giblets and cut off tail and neck. Rinse birds under cold water.
5. Evenly distribute one heaping teaspoon seasoning inside chicken cavity. Uniformly dust outside with exception of wings. Too much seasoning will darken or burn wings.
6. Set spit into prep station holder. Place birds on spit by folding wings back and crossing legs.

## Cooking:

**⚠ WARNING:** All surfaces are HOT. Hot surfaces could cause serious burns. Use hot mitts when handling unit components.

1. After preheating, turn unit OFF.
2. Install pre-loaded spit in unit and close doors. If desired, install door lock over front door handles.

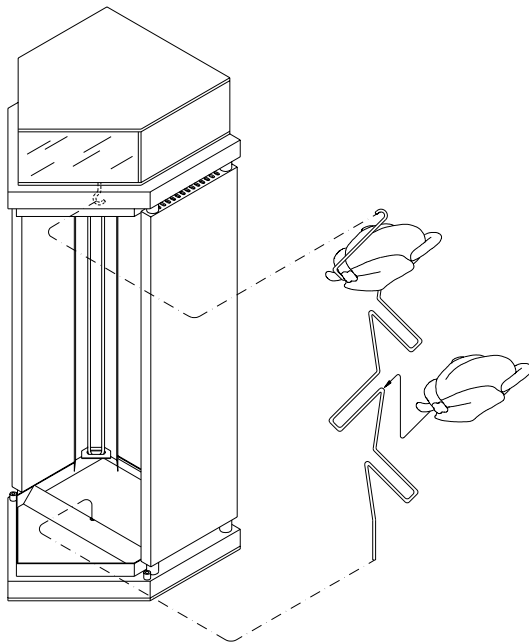

3. Turn ON. Set TIME according to COOKING CHART.
4. When TIME reaches 0, unit will switch to IDLE. Allow birds to hold for 5 minutes minimum before serving.
5. Turn POWER switch OFF before removing birds. Press JOG switch until birds on one side of spit are easily accessible. Using tongs, remove birds.
6. Using poultry shears, cut down center of breast. Turn over and cut down each side of backbone. Quarter halves by separating thigh & leg and breast & wing.

## COOKING CHART

Bird Size	Suggested Cook Times	
	120/208 Volt	220/240 Volt
2.50 - 2.75 lb.	90 min.	80 min.
2.75 - 3.00 lb.	100 min.	90 min.
3.00 - 3.25 lb.	110 min.	100 min.

Times above are suggested minimum cook times. An additional 10 minutes could be used to reduce moisture in the product.

## CLEANING

**⚠ WARNING:** Wait for unit to cool before cleaning. Hot surfaces could cause serious burns. DO NOT attempt to clean hot glass. Glass may break causing serious cuts.

Clean once daily using a household dish cleanser.

1. Disconnect main power supply.
2. Remove doors by fully opening and lifting up and out on bottom; set in sink for cleaning. DO NOT use abrasive cleaners on glass. To install doors, insert upper pin first followed by lower pin.
3. Remove spit and drip pan. Set parts in sink for cleaning. After reflector has cooled, loosen thumb screws and remove for cleaning.
4. Wipe unit interior with clean cloth or paper towel.

**⚠ WARNING:** Rags or papers containing cooking oil can catch fire if exposed to heat. Laundering will not remove the oil. Dispose of all oil-soiled papers and rags in a trash container that is in a ventilated area away from all cooking equipment or other heat sources such as direct sunlight.

# PARTS AND ACCESSORIES

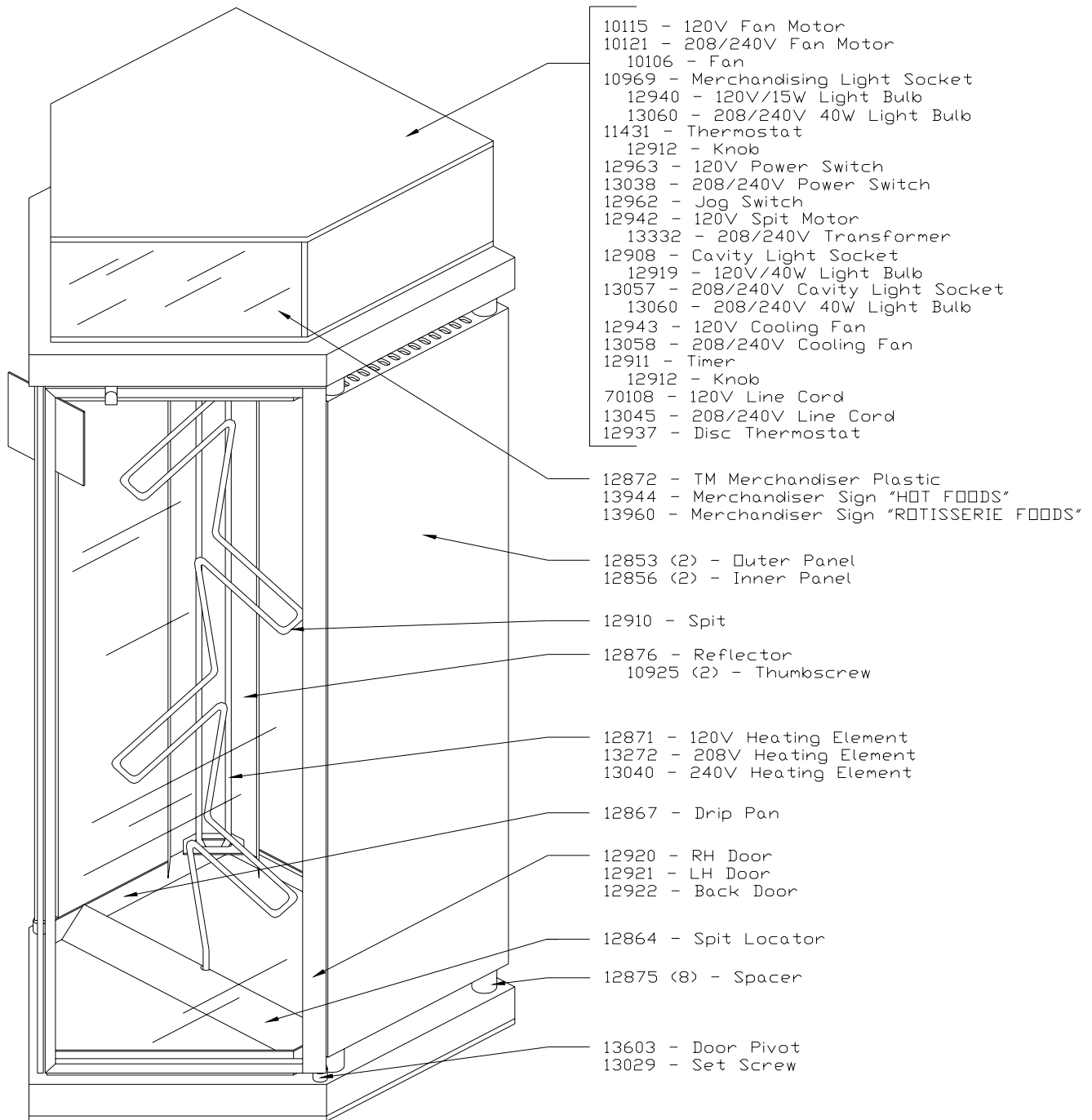

Not Shown:

- |                       |                             |
|-----------------------|-----------------------------|
| 00378 - Short Tongs   | 12944 - Door Lock           |
| 06524 - Full Size Pan | 60000 - Poultry Shears      |
| 12900 - Prep Station  | 93097 - Large Shaker Bottle |

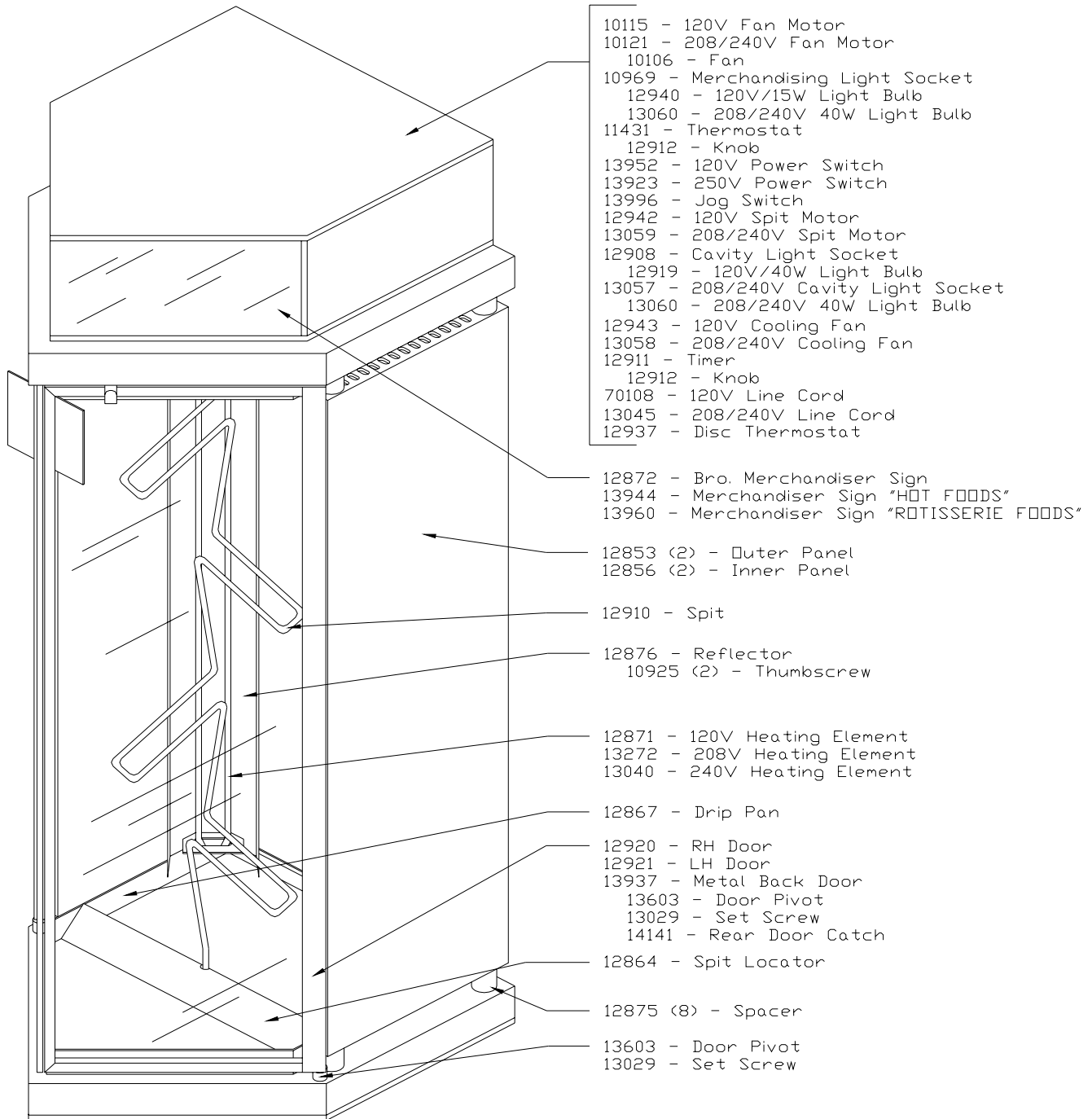

Not Shown:

- |                       |                             |
|-----------------------|-----------------------------|
| 00378 - Short Tongs   | 60000 - Poultry Shears      |
| 06524 - Full Size Pan | 93097 - Large Shaker Bottle |
| 12900 - Prep Station  |                             |