

THE BROASTER COMPANY

VF-3 Ventless Fryer

- **Self venting** – no costly installation of expensive hoods and vents (check local restrictions, requirements vary).
- **Fits almost anywhere** – requires only 25" x 23" of countertop space and stands just 27½" tall.
- **Programmable, solid-state controller** – features dual digital display providing a visual countdown of cook time as well as confirmation of set and actual cooking temperatures.
- **Easy to operate** – utilizes Broaster's handy Temp 'N Time feature that allows any one of 10 preset time and temperature combinations to be recalled with the touch of a button, assuring consistent cooking quality and simplifying staff training.
- **Exclusive Information Center** – assures all critical components are installed and operating properly.
- **Proven round cooking well design** – engineered for consistent heat distribution, durability, and efficiency.
- **Autolift feature** – raises and lowers the lift basket in the cooking well automatically.
- **Large basket capacity** – well beyond competitive offerings for more product per load
- **Built-in fire suppression system** in accordance with NFPA 17A and resettable high temp limit switch for added safety.

NEW

NEW

NEW



*Certified in accordance with the following standards: **UL197** for Commercial Electric Cooking Appliances, **UL710B** Outline of Investigation for Recirculating Systems, **CSA C22.2 No. 109-M** Commercial Cooking Appliances, and **ANSI/NSF4** Commercial Cooking, Rethermalization, and Powered Hot Food Holding Equipment.*

Team the VF-3 ventless fryer with our full line of Broaster® Recipe ready-to-cook frozen foods for an innovative, affordable, and complete licensed trademark program that's ideal for convenience stores, taverns, snack bars, kiosk operators, or anyone who wants to profit by having a quality hot food menu!

See our **Broaster® Recipe Express Program** brochure for complete program details.

The Broaster Company

2855 Cranston Road, Beloit, WI 53511
(800) 365-8278 • (608) 365-0193
Fax (608) 363-7957 • www.broaster.com

An American Tradition Since 1954!

THE BROASTER COMPANY

VF-3 Ventless Fryer

OPERATION



Convenient front access door-within-a-door allows basket preloaded with product to be inserted into the unit with a minimum of heat escape and oil cooling.

Then just choose the appropriate setting on the VF-3's Time 'N Temp solid-state controller and press the start button.

Autolift device automatically lowers basket into the cooking oil.



Upon completion of cooking cycle, an indicator sounds and basket is automatically lifted from the cooking oil.

Simply remove basket through door and you're ready to serve hot and delicious grab 'n go foods.

SPECIFICATIONS

PART NUMBER	MODEL NUMBER	PRODUCT CAPACITY	OIL CAPACITY	SHIPPING WEIGHT
85884 (208v), 85885 (240v)	VF-3	3 lbs. per load (1.36 kg per load)	21 lbs. [2.78 gallons] (9.53 kg [10.52 liters])	140 lbs. (63.5 kg)

The Broaster Company

2855 Cranston Road, Beloit, WI 53511
(800) 365-8278 • (608) 365-0193

Fax (608) 363-7957 • www.broaster.com

INFORMATION CENTER



The VF-3's Information Center – a Broaster exclusive – identifies that all critical components are installed and operating properly. When a fault condition is sensed, operator is locked out from starting cooking cycle until the fault condition is corrected. Tripping of high limit control or opening full access door will halt cooking cycle in process until indicated condition is corrected.

OVERALL DIMENSIONS

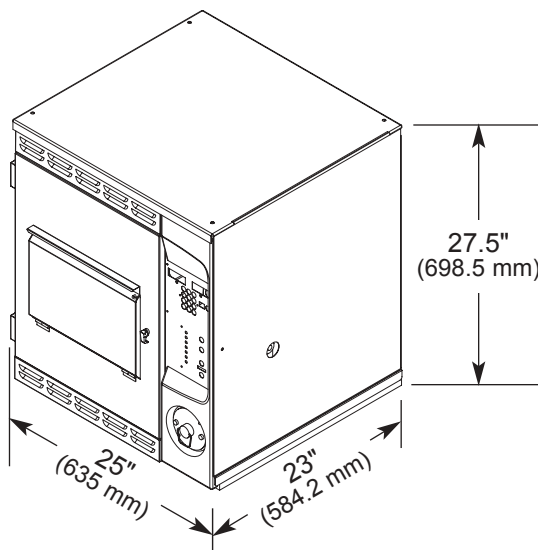

ELECTRICAL REQUIREMENT

120/208V, 1Ph, 60Hz, 26.5 amps or 120/240V, 1Ph, 60Hz, 23 amps – 4 wire with ground and neutral.

(To be field wired in accordance with ANSI/NFPA 70 or CSA C22.2)

An American Tradition Since 1954!