

# Landing and Dump Tables

- **Safe and convenient** – these must-have tables provide sanitary working conditions and plenty of storage space for extra pans, grates, utensils, and other kitchen accessories.
- **Great mobility** – with four swivel casters these tables can be moved anywhere they are needed in your kitchen.
- **Functional and sturdy** – stainless steel work surfaces are durable and easy to clean after use.
- **Perfect for any kitchen** – dump table's high side frame prevents product spill-over and food loss when unloading fry baskets. Landing table has flat countertop surface, perfect for holding pans while you load your Broaster® fryer, or as a table top for supporting other equipment.



Dump Table



Landing Table

*Durable, convenient, and easy to use!*



# Landing and Dump Tables

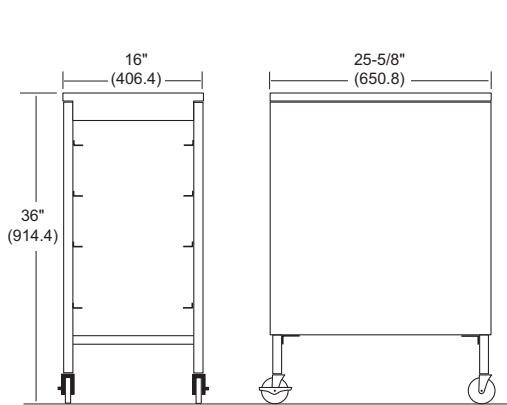

85211 Landing Table

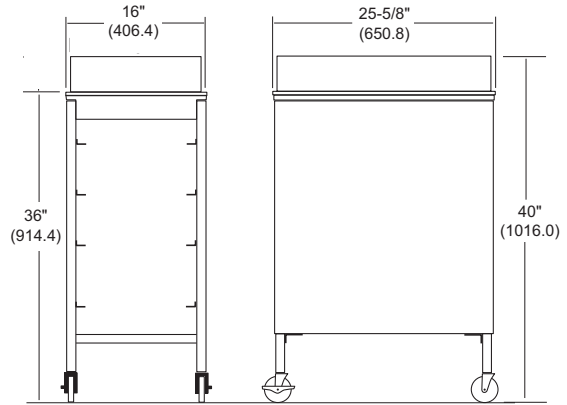

85212 Dump Table

Inches  
(Millimeters)

## SPECIFICATIONS

PART NUMBER	OVERALL DIMENSIONS			OVERALL HEIGHT	NET/SHIP WEIGHT
	W	D	H		
85211	16" (406.4)	25.625" (650.8)	36" (914.4)	36" (914.4)	41/44 lbs. (18.6/19.9 kg)
85212	16" (406.4)	25.625" (650.8)	36" (914.4)	40" (1016.0)	46/50 lbs. (20.9/22.7 kg)

## ADDITIONAL FEATURES

- Both tables feature frames made from welded #16 gauge stainless steel and sides and tops made from #20 gauge grained stainless steel.
- Both tables include 4-tray slots, designed to hold standard 12" x 20" pans (pans not included).
- Both tables have four swivel casters for easy mobility, two of which are locking.
- Dump table's dumping frame is removable for easy cleaning and made from welded #20 gauge grained stainless steel.
- Landing table's countertop is made from #20 gauge grained stainless steel and provides portable workspace anywhere in your kitchen for accessory equipment such as the Broaster Model 620 Easy Breader/Marinator or the Broaster Potato Wedger.

