

Snack-Mate™ Radiant Broiler

- **The ideal electric broiler** for consistent, high-quality broiling of a wide range of foods.
- **High intensity infra-red rays** cook and warm foods to perfection.
- **Convenient warming drawer** for buns and holding pans for cooked product included.
- **Compact footprint** allows this unit to fit practically anywhere. Perfect for every size operation, from snack-shop to full-service restaurant.
- **Easy clean-up** via removeable broiling grid and slide-out drip pan drawer.
- **Venting Not Required** in most areas (check local requirements).



Versatile, convenient, and easy to use!



Snack-Mate™ Radiant Broiler

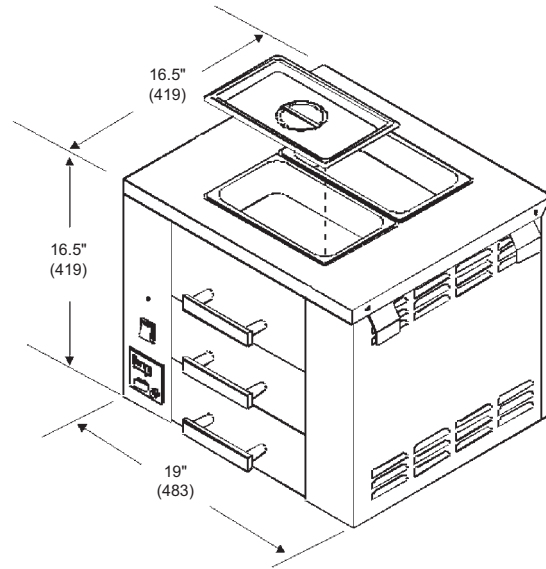

Inches
(Millimeters)

SPECIFICATIONS

OVERALL DIMENSIONS			NET/SHIP WEIGHT	CUBES
W	D	H		
19" (483)	16.5" (419)	16.5" (419)	50/59 lbs. (22.7/26.8 kg)	5.89

ENERGY REQUIREMENTS

120V, 60 Hz, 12.5 Amps,
1 Heating Element: 1500 Watts
(3-wire grounded 4' cord & plug included)

ADDITIONAL FEATURES

- Exterior made of durable stainless steel.
- Easy-to-operate digital timer for accurate cook times.
- Audible beep to indicate completed cook cycle.
- Thermostat keeps broiler preheated, ready to broil when time is set.
- Two 2½" deep, quarter-size, heavy-duty stainless steel holding pans with lids included.
- Side and rear access panels make servicing easy.

