

Model 765

Portable Filter

- **Extend oil life** – filtering your cooking oil helps to extend its life, reducing shortening costs while maintaining food quality.
- **Quick filtering** – 3.5 gallons per minute throughput allows you to filter 65 pounds of hot cooking oil in under five minutes.
- **Easily portable and compact** – durable lightweight unit has two swivel and two stationary casters, pull handle folds down for compact storage.
- **Convenient** – filters cooking oil and returns it to the fryer in a clean, ready-to-cook condition.
- **Safe and easy** – hot oil is safely enclosed inside the unit at all times for easier and safer handling.



The perfect oil filter for any size fryer!



Model 765

Portable Filter

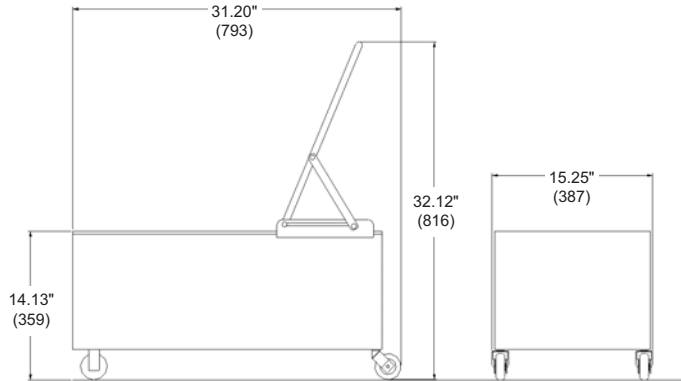

Inches
(Millimeters)

SPECIFICATIONS

COOKING OIL CAPACITY	OVERALL DIMENSIONS			TANK HEIGHT	UNIT NET WEIGHT	SHIPPING WEIGHT	CUBES
	W	D	H				
65 lbs.	15.25" (387)	31.20" (793)	32.12" (816)	14.13" (359)	80 lbs.	95 lbs.	6.68

ENERGY REQUIREMENTS

120V, 60 Hz, 9 Amps
(6' cord & plug included)

ADDITIONAL FEATURES

- 1/3 H.P. capacitor start motor.
- Easy to clean and maintain.
- High temperature flexible hose with nickel-plated wand and handle are specially designed to keep cool to the touch, making unit safer to operate.
- Cover prevents objects from falling into the filtering pan.
- Allows use as a gravity fill in addition to the power fill and power return feature.
- Unique independent heat control melts solid shortening to keep piping open and free flowing.
- Specially designed filter paper and filtering compounds are available to help increase the oil life.

