

# Model 2400

## Pressure Fryer

- **Fast and productive** – specifically designed for high volume production, cooks up to 64 pieces of fresh bone-in chicken per load in under 10 minutes!
- **Proven round cooking well design** – engineered for more uniform heat distribution, durability, and efficiency; no cold spots or corners. Large capacity provides more room for product, minimizes sticking, and produces delicious, superior quality food.
- **Unique Auto Comp™ feature** – automatically adjusts cooking time to accommodate for varying sizes and temperatures of loads.
- **Exclusive counter-balance lift system** – quick closing and opening single action sealing is designed for safety and ease of use.
- **Built-in filter system** – provides quick, easy, and safe cooking oil filtration; no heated fittings to disconnect.
- **Automatic cook cycle counter** – monitors production between filtering.
- **Easy to operate** – one-of-a-kind Temp-N-Time™ feature offers the capability to pre-program up to 10 different cook cycles for quick and easy preparation of various menu items. Solid-state controller is backed by a 2-year warranty.



CE approved machines available.

*The only brand of equipment authorized for producing Genuine Broaster Chicken®!*



# Model 2400 Pressure Fryer

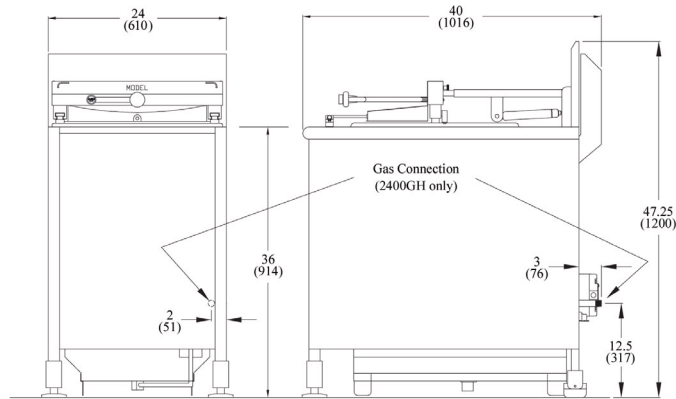

Inches  
(Millimeters)

## SPECIFICATIONS

MODEL	FRESH CHICKEN CAPACITY	COOKING OIL CAPACITY	OPERATING PRESSURE	OVERALL DIMENSIONS			COUNTER HEIGHT	NET/SHIP WEIGHT	CUBES
				W	D	H			
2400E and 2400GH	22 lbs./ load 110 lbs./ hour	63 lbs.	12 - 14 P.S.I.	24"	40"	47.25"	36"	2400E 360/410 lbs. 2400GH 407/457 lbs.	26.25
				(610)	(1016)	(1200)			

## ENERGY REQUIREMENTS

2400E	Three Phase 208V - 42 Amps - 60 hz 240V - 40 Amps - 60 hz 220/380V - 29.5 Amps - 50/60 hz 240/415V - 26.3 Amps - 50/60 hz <i>(Note: this model cannot be converted to single phase)</i>
2400GH	100,000 BTU - 120V - 15 Amp**

\*\*6' cord and plug included

### Main Burner Orifice

Natural Gas: #14 Drill, LP Gas: #32 Drill

*Note: Specifications indicated above are for elevations up to 2,000 feet. For higher elevations, consult your authorized Broaster distributor for proper orifice size.*

### Pilot Burner Orifice

Natural Gas: .018", LP Gas: .011"

## ADDITIONAL FEATURES

- Durable, welded, tubular steel frame is powder-coated to resist corrosion.
- Advanced solid state controls provide easy operation and dependability.
- Unique rear feet glides are specially designed to move unit across flooring.
- Stainless steel top and side panels offer durability and easy cleaning.
- Unique stainless steel basket with a ratchet-style removable basket handle plus two fixed handles allow easier unloading of product.

## ACCESSORIES AVAILABLE

Basic Accessory Kit • Complete Start-up Accessory Kit • Rear Wheels

